

ASGM18A

AXIe Advanced Signal Generator: 100 MHz to 18 GHz



- Frequency range: 100 MHz to 18 GHz with 1 Hz resolution
- Frequency switching: $< 1 \mu\text{s}$
- Real-time control of frequency, phase and amplitude: BCD parallel
- PC control of frequency, phase and amplitude: PCIe and USB
- Upconversion: 1 GHz instantaneous bandwidth
- Multi-channel phase coherent operation

Giga-tronics

Solutions for Next Gen EW / Radar Test & Deployment

The Giga-tronics ASGM18A AXIe Advanced Signal Generator (ASG) is a real-time RF signal generator over the frequency range of 100 MHz to 18 GHz. With the upconverting option, it is used for emulating agile, low-noise emitters anywhere within that same wide frequency range. As an RF Upconverter, the ASGM18A can be used to generate complex, wide bandwidth signals for testing Radar and EW systems. The modular ASGM18A is built in the industry standard AXIe form factor and works in conjunction with the Giga-tronics SRM100A System Reference Module and either the CHSIS2A AXIe 2-channel or CHSIS4A AXIe 4-channel chassis for multi-channel, phase coherent operation.

- Frequency range: 100 MHz to 18 GHz with 1 Hz resolution
- Frequency switching: < 1 μs
- Real-time control of frequency, phase and amplitude: BCD parallel
- PC control of frequency, phase and amplitude: PCIe and USB
- Upconversion: 1 GHz instantaneous bandwidth
- Multi-channel phase coherent operation

This datasheet provides a summary of the key performance parameters for Giga-tronics ASGM18A AXIe Advanced Signal Generators. All specifications apply over a +20 °C to +30 °C temperature range after a 30 minute warm-up period unless otherwise noted.

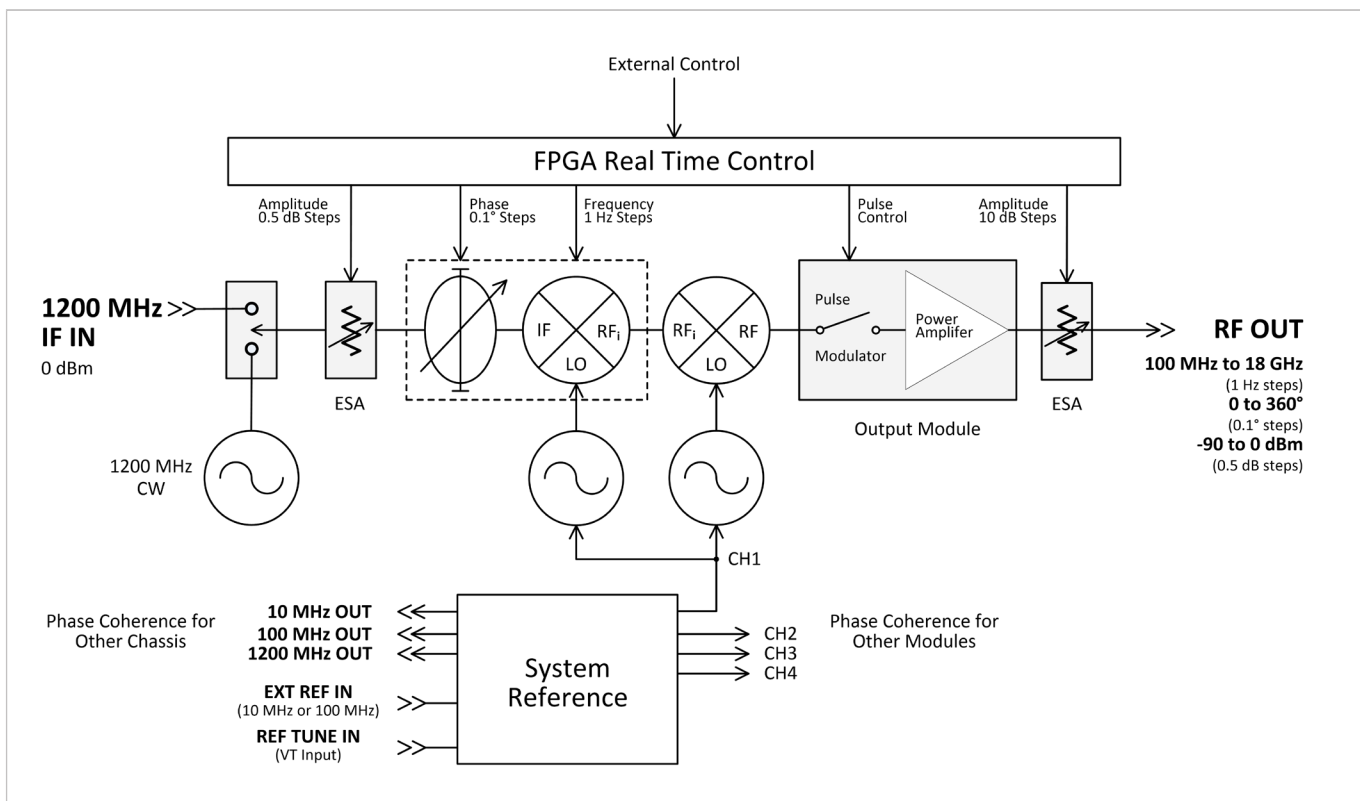

Figure 1 The ASGM18A RF and Control Block Diagram

PER CHANNEL SPECIFICATIONS

RF Output: General Characteristics

Frequency Range	100 MHz to 18 GHz
Frequency Resolution	1 Hz
Phase Adjustment Range	0 to 360 Degrees
Phase Resolution	0.1 Degrees
Channel to Channel Phase Stability	< 0.5 degrees over 30 days
Inter-channel Isolation	> 100 dB
Output Impedance	50 Ω
Output VSWR	< 2.0:1
Output Connector	Type-N (F)

RF Output Power: CW Mode

Maximum Available Power ¹	
Standard	+10 dBm
OPT-ATT	0 dBm
Minimum Settable Power	
Standard	0 dBm
OPT-ATT	-90 dBm
Resolution	0.5 dB
Power Accuracy	
> -5 dBm	± 1.7 dB
- 5.0 to -10.5 dBm	± 1.5 dB
-11.0 to -60.5 dBm	± 2.3 dB
-61.0 to -90 dBm	± 2.8 dB

Upconverting Mode (OPT-UP1)²

IF Input Center Frequency	1200 MHz
Maximum Available Power ¹	
Standard	+10 dBm
OPT-ATT	0 dBm
Minimum Settable Power	
Standard	0 dBm
OPT-ATT	-90 dBm
Resolution	0.5 dB
IF to RF Conversion Gain	0 dB (with attenuation set to 0 dB and IF Input level \leq 0.0 dB)
Instantaneous Bandwidth	See Figure 2
Power Flatness	See Table 1
Group Delay	< 20 ns nominal
Group Delay Variation	± 500 picoseconds maximum
Spectral Polarity	User selectable (between inverting and non-inverting)

1 Specifications typically degrades <2 dB from 30°C to 50°C

2 Specifications apply with IF input power = 0 dBm

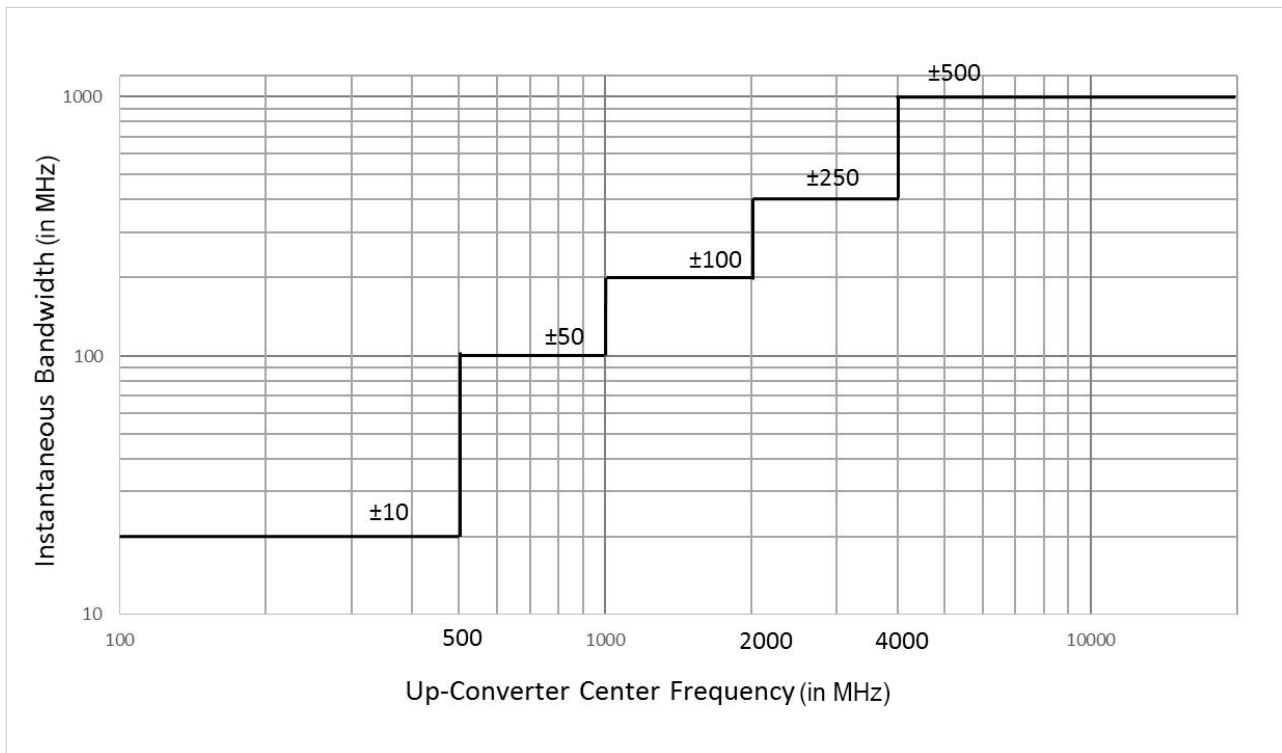

Figure 2 - IF Bandwidth versus Output Carrier Frequency

RF Power Flatness (dB RMS)

CARRIER FREQUENCY (MHz)	INSTANTANEOUS BANDWIDTH				
	± 10 MHz	± 50 MHz	± 100 MHz	± 250 MHz	± 500 MHz
100 to 500	0.1 dB				
500 to 1,000	0.1 dB	0.6 dB			
(L-Band) 1,000 to 2,000	0.1 dB	0.6 dB	1.1 dB		
(S-Band) 2,000 to 4,000	0.25 dB	0.6 dB	1.1 dB	1.7 dB	
(C-Band) 4,000 to 8,000	0.1 dB	0.6 dB	1.1 dB	1.7 dB	1.9 dB
(X-Band) 8,000 to 12,000	0.1 dB	0.6 dB	1.1 dB	1.7 dB	1.9 dB
(Ku-Band) 12,000 to 18,000	0.1 dB	0.6 dB	1.1 dB	1.7 dB	1.9 dB

Table 1 - RF Output Power Flatness using 1200 MHz IF Input in Uncovering Mode

Spectral Purity

Harmonics ³ 100 MHz to 2.0 GHz 2.0 GHz to 18.0 GHz > 18 GHz	≤ -60 dBc (< -65 dBc nominal) ≤ -55 dBc (< -60 dBc nominal) ≤ -60 dBc (nominal)
Spurious ⁴ (offsets > 300 kHz) 100 MHz to 2.0 GHz 2.0 GHz to < 12.3 GHz 12.3 GHz to 18.0 GHz	≤ -60 dBc (< -65 dBc nominal) ≤ -65 dBc (< -70 dBc nominal) ≤ -60 dBc (-65 dBc nominal)
AM Noise (offsets > 10 MHz) ⁴	-130 dBm/Hz typical

Measured Spectral Purity

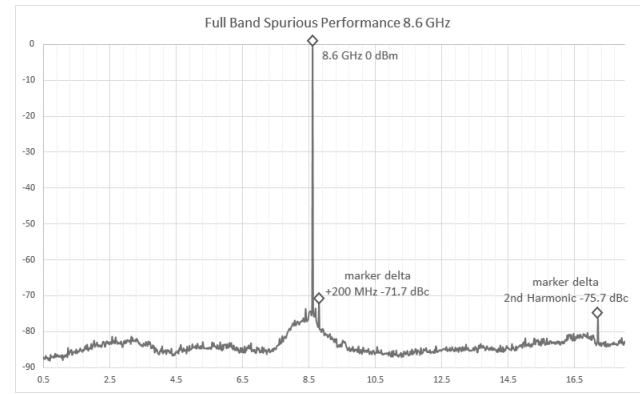
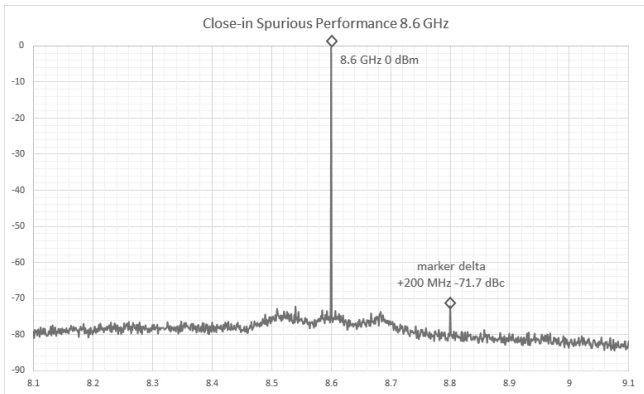
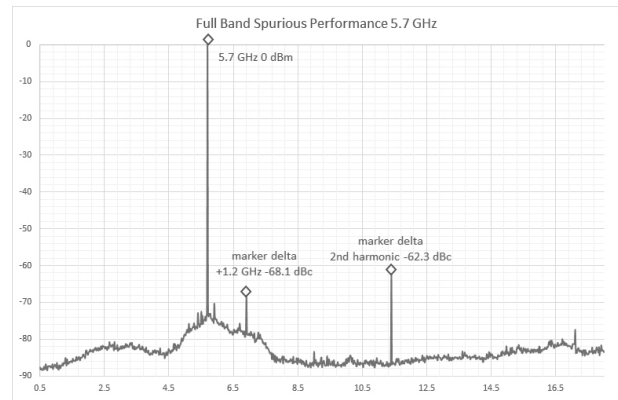
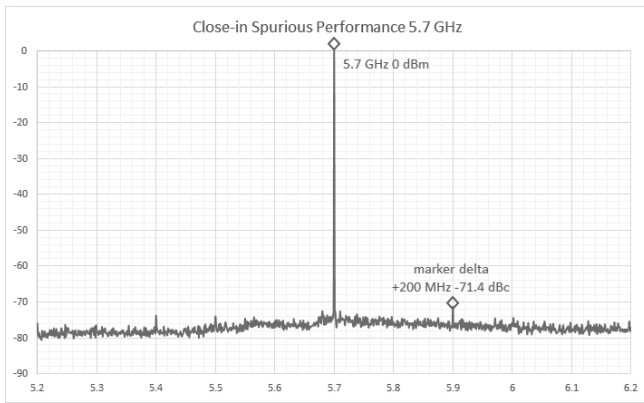

- 3 Output Power = 0 dBm (-10 dBm with OPT-ATT)
- 4 Output Power = +10 dBm (0 dBm with OPT-ATT)

Measured Spectral Purity: cont'd

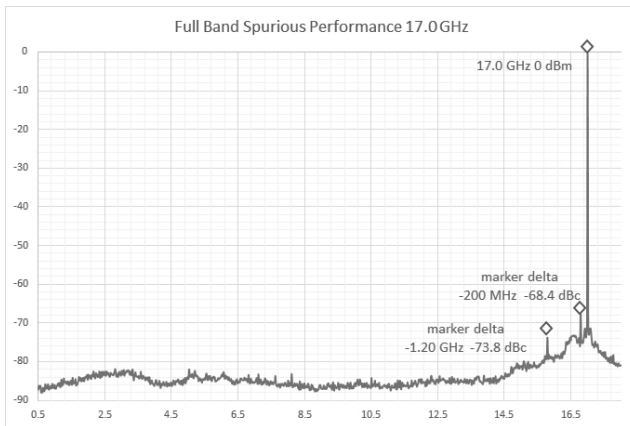
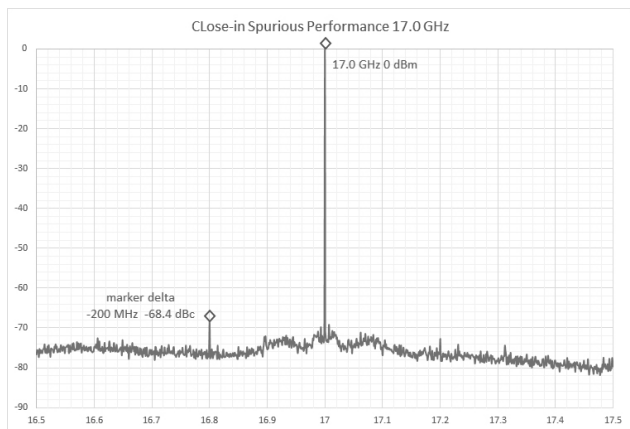
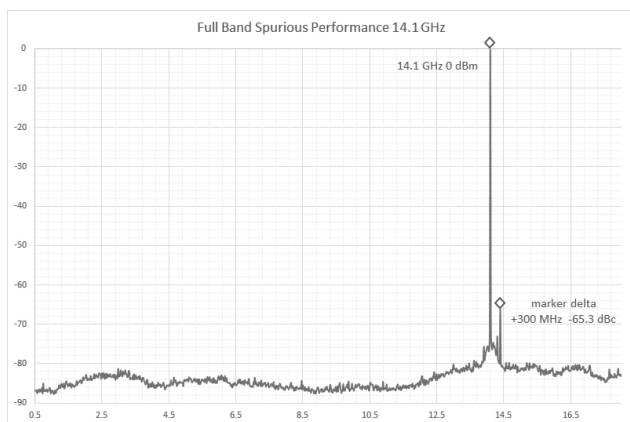
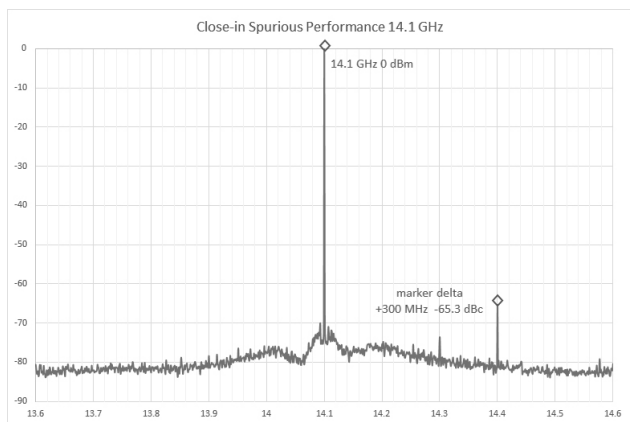
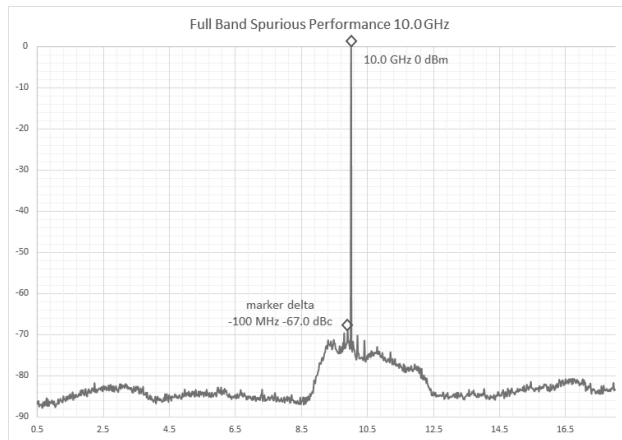
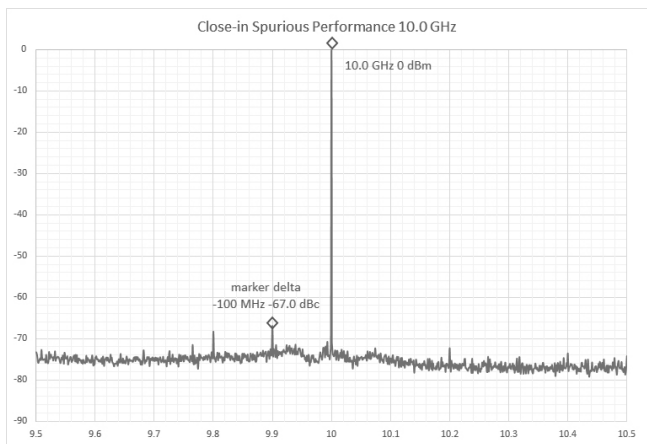

SSB Phase Noise

Frequency (GHz)	Offset from Carrier (dBc/Hz)							
	1 Hz	10 Hz	100 Hz	1 kHz	10 kHz	100 kHz	1 MHz	10 MHz
4.0	-54	-82	-95	-99	-118	-126	-130	-130
10.0	-47	-76	-89	-98	-115	-125	-130	-130
16.0	-44	-72	-85	-96	-113	-124	-129	-129

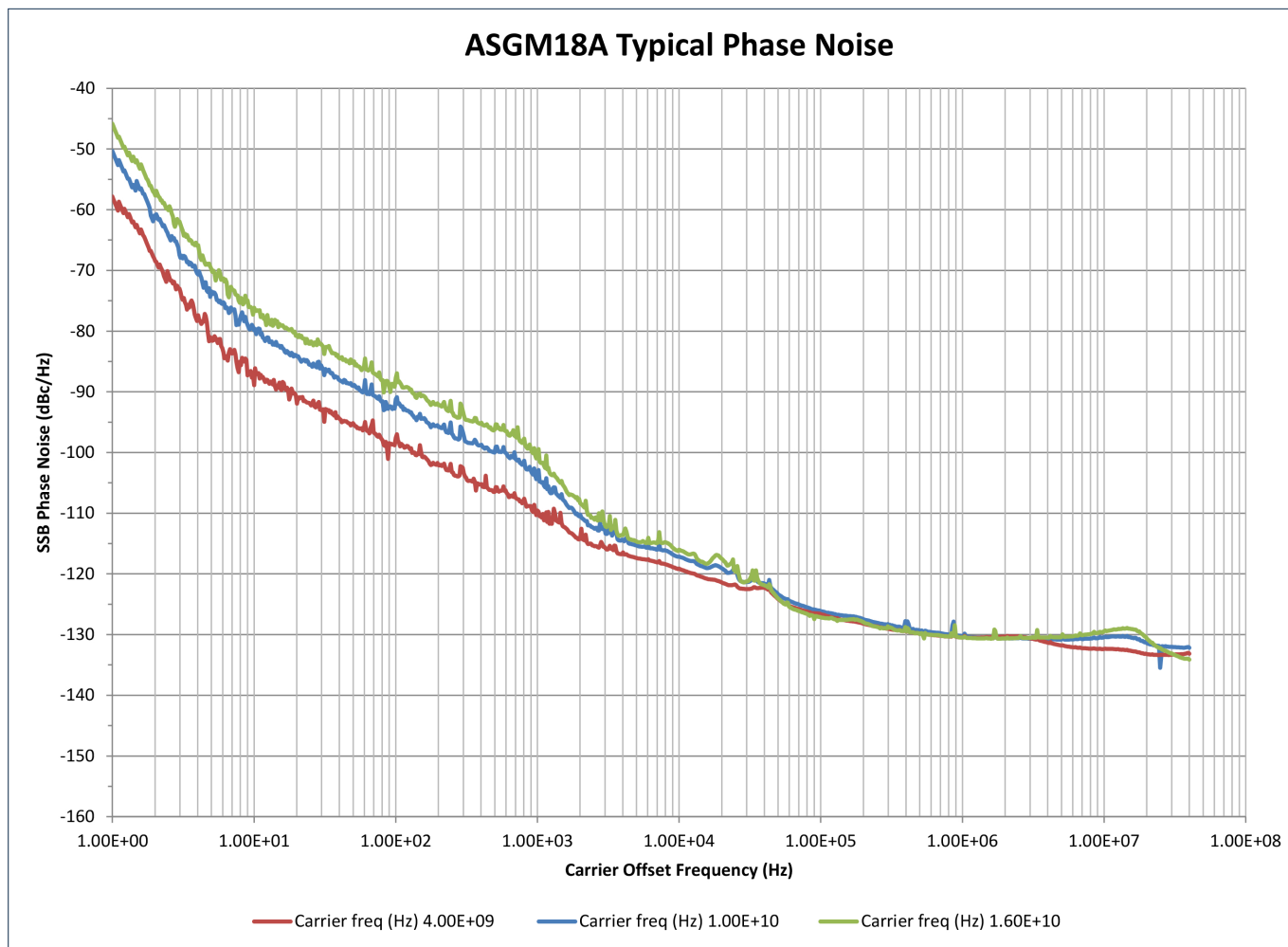

Figure 3 - Single Sideband Phase Noise at Various Center Frequencies

Frequency Switching Characteristics

Phase Coherent Frequency Switching	Full bandwidth 1 Hz resolution
Frequency Settling Time ⁵	< 300 ns
Phase Settling Time ⁶	< 300 ns
Latency	117 ns ± 2 ns
Trigger Input	Edge-triggered 50 ns min PW {front panel SMA (F)}
Trigger Polarity	Rising or falling edge (user selectable)
Sync Output	50 ns PW (nominal)
Sync Output Delay	75 ns to 200 μs from Trigger Input (user selectable)
Amplitude Settling Time ⁷	< 650 ns
RF Output Blanking Time	25 ns to 200 μs PW (user selectable)

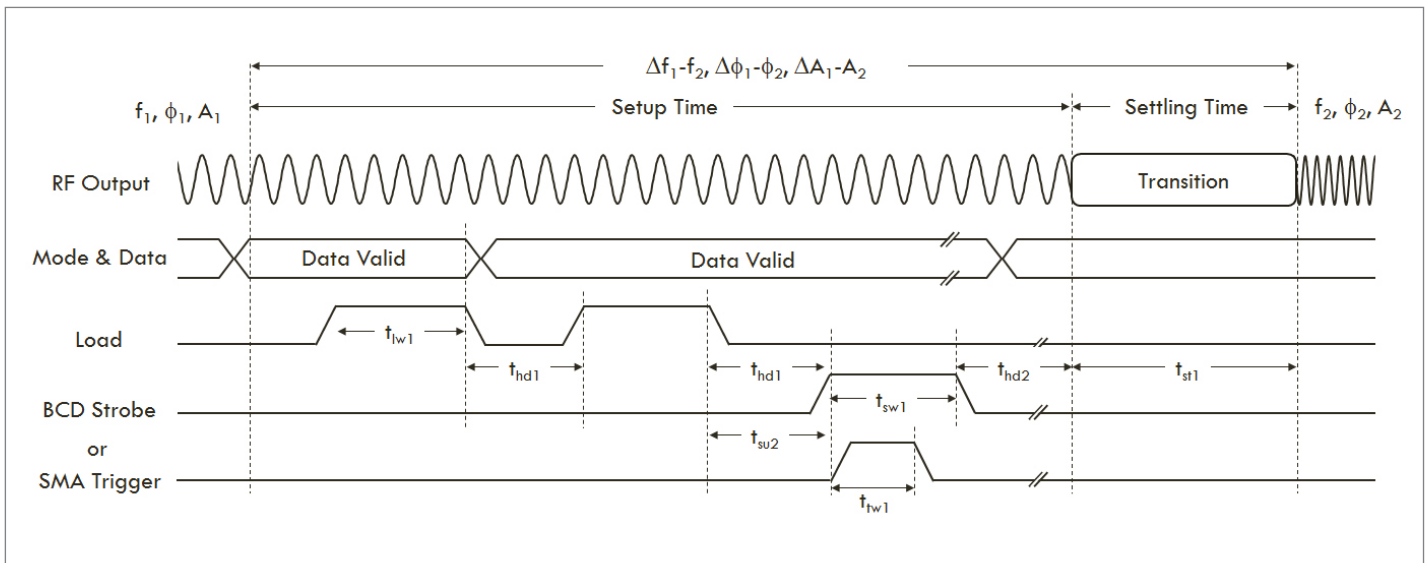

Figure 4 - ASGM18A Switching Speed Definitions and Timing

Frequency Switching Characteristics Nominal Performance

Parameter	Description	Min
t_{sw1}	BCD Strobe width	60 ns
t_{hd1}	Hold time - data stable while load is de-asserted	40 ns
t_{lw1}	Load width	60 ns
t_{hd1}	Hold time - data stable while BCD strobe is de-asserted	40 ns
t_{su1}	Setup time	60 ns
t_{tw1}	Trigger width	30 ns
t_{su2}	Setup time	40 ns
t_{hd3}	Hold time - data stable while SMA trigger is de-asserted	30 ns
t_{st1}	Settling time	300 ns

5 Time for frequency to settle within 1 Hz of final value after receiving a trigger.
 6 Time for phase to settle within 0.1 degree of final value after receiving a trigger.
 7 Time for amplitude to settle within 0.5 dB of final value after receiving a trigger.

RF Gate Characteristics

ON/OFF Ratio	> 80 dB
Rise/Fall Time (10-90%) 100 MHz to < 500 MHz ≥ 500 MHz to 18 GHz	< 50 ns < 10 ns
Minimum RF Pulse Width 100 MHz to < 500 MHz ≥ 500 MHz to 18 GHz	100 ns 20 ns
Pulse Repetition Interval	100 ns to CW
Video Feed-through 100 MHz to < 500 MHz ≥ 500 MHz to 18 GHz	< 5% of signal voltage < 1% of signal voltage
Time Compression	< ± 5 ns
RF Gate Latency	< 75 ns
Input Sensitivity	TTL levels (selectable polarity)
Input Impedance	50 Ω

Instrument Control

Parallel Interface (Option BCD) Frequency Control Amplitude Control Phase Control	Positive TRUE, BCD format, 11 digits with TTL strobe Positive TRUE, BCD format, 3 digits with TTL strobe Positive TRUE, BCD format, 4 digits with TTL strobe
Serial Interface	Mini-USB (full instrument control using Advanced Signal Control Software)
PCIe	2 lane PCIe (full instrument control using Advanced Signal Control Software)

System Control

PCIe	PCIe X8 GEN2 (full instrument control)
Ethernet	10/100/1000 Mbps (chassis status only)
Graphical User Interface	Advanced Signal Control Software
Programming Interface	Giga-tronics Proprietary API (GTSigGen.dll, GTSigConn.dll)

Inputs and Outputs

Parallel Interface	Digital control hardware input (OPT BCD)
Sync Out	TTL output pulse
Trigger In	Accepts TTL input signal > 50 ns width
1200 MHz IF In	Up-converting input (OPT UP1) / SMA(F)
Pulse In	50 Ω TTL level input (polarity selectable)
Pulse Out	50 Ω synchronization TTL output pulse

General Specifications

Environmental	MIL-PRF-28800F for Temperature, Humidity and Altitude only. Operating Random Vibration: 5 to 500 Hz, 0.21 grms. Survival Random Vibration: 5 to 500 Hz, 2.09 grms
Safety	EN61010-1:2010
Emissions	EN61326-1:2013
Weight ASGM18A 2-CH Systems 4-CH Systems	16 lbs Up to 89 lbs (40.4 kg) depending upon configuration Up to 146 lbs (66.2 kg) depending upon configuration
Dimensions ASGM18A 2-CH Systems 4-CH Systems	2.5" H x 13.75" W x 12.0" D 7.25" H X 19.0" W X 24.5" D 12.3" H X 19.0" W X 24.5" D
Power ASGM18A 2-CH Systems 4-CH Systems	< 200 Watts < 450 Watts (include chassis) < 900 Watts (include chassis)
Form Factor	AXIe

Selection Guide by Application

Model Number	APPLICATION				OPTIONS			
	Real-Time Synthesizer	AXIe Companion	Real-Time Threat Emulation	Radar Quiet Target Generator	OPT-ATT Electronic Step Attenuator	OPT-UP1 1200 MHz IF Input	OPT-BCD Parallel BCD Input	OPT-TCI TEmS Control Interface
ASGM18A 100 MHz to 18 GHz Advanced Signal Generator Module	●	●	●	●	●	●	●	●
ASAM18A 500 MHz to 18 GHz Advanced Signal Analyzer Module		●	●				●	
SRM100A System Reference Module	●	●	●	●				
CHSIS2A / CHSIS4A 2-Channel or 4-Channel AXIe System Chassis	●	●	●	●				
CHSISBK AXIe Blank Module: 2-Slot	●	●	●	●				
ONS On-Site System Configuration Service	●	●	●	●				
TEmS Threat Emulation Software and Control System			●					

Ordering Information

Model Number	Description
ASGM18A OPT-ATT OPT-UP1 OPT-BCD OPT-TCI	AXIe Advanced Signal Generator: 100 MHz to 18 GHz Electronic Step Attenuator for 90 dB Dynamic Range 1200 MHz Upconverter IF Input Parallel BCD Input Control Interface TEmS Control Interface
ASAM18A OPT-BCD	AXIe Advanced Signal Analyzer: 500 MHz to 18 GHz Parallel BCD Input Control Interface
SRM100A	AXIe System Reference Module: 10 MHz, 100 MHz, 1200 MHz
CHSIS2A	2-Channel AXIe System Chassis (4U) (For 1 or 2 channel systems)
CHSIS4A	4-Channel AXIe System Chassis (7U) (For 1 to 4 channel systems)
CHSISBK	AXIe Blank Module: 2-Slot cover for Airflow Management and Backplane Termination
EWS20	Extended 2 Year Warranty
EWS40	Extended 4 Year Warranty
Consultancy	Professional Consultation

Standard Warranty



Giga-tronics warrants to the Customer that all manufactured products conform to published specifications and are free from defects in material and workmanship for one year. The period begins on the date of shipment and only applies to normal operation of the product within the appropriate service condition. Giga-tronics shall have no responsibility hereunder for any defect or damage caused by improper storage, improper installation, unauthorized modification, misuse, neglect, inadequate maintenance, accident, or any part which has been repaired or altered by anyone other than Giga-tronics or its authorized representative, or not in accordance with Giga-tronics furnished instructions. <https://go-asg.gigatronics.com/warranty>

Extended Warranty



Extended warranty (Service and Calibration) can only be purchased at time of ordering or within 30 days after the ship date. Service for extended warranties will be performed by Giga-tronics Incorporated, its Microsource subsidiary; or, an authorized Giga-tronics Service Center. Prices do not include freight, insurance, handling, taxes, duties or any other related shipping charges. Extended warranty service and extended calibration options are based on the original ship date of the product. Extended calibration option requires that units be calibrated annually, if applicable. <https://go-asg.gigatronics.com/warranty>



American Systems Registrar, LLC certified ISO 9001:2008
 Certification: <https://go-asg.gigatronics.com/quality>

ISO 9001:2008

Giga-tronics Support Services

At Giga-tronics, we understand the challenges you face. Our support services begin from the moment you call us. We help you achieve both top-line growth and bottom-line efficiencies by working to identify your precise needs and implement smart and result orientated solutions. We believe and commit ourselves in providing you with more than just our superior test solutions. For technical support, contact:

Phone: +1 925.328.4650 | Email: asg-info@gigatronics.com

All data is subject to change without notice. For the latest information on Giga-tronics products and applications, please visit : <https://go-asg.gigatronics.com>